



Air dehumifiers
DEH-500i / DEH-900i / DEH-1200i

» Manual



rev. 3.12

CONTENT

Introduction	3
Purpose	3
Content	3
Copyright	3
1. SAFETY AND APPLICATION	4
1.1 Safety of use	4
1.2 Application area	5
2. DEVICE INFO	5
2.1 Standards	5
2.2 Description and principle of operation	5
2.3 Design	6
3. MOVEMENT AND INSTALLATION SITE	7
4. STARTING AND OPERATION	7
4.1 Electrical connection	7
4.2 Control Panel	8
4.3 How to operate and set parameters	8
5. MAINTENANCE	9
5.1 Introduction	9
5.2 Frame	9
5.3 Filter	9
5.4 Heat exchanger	9
5.5 Fan motor	10
5.6 Compressor refrigeration system	10



SAVE THIS MANUAL FOR FUTURE USES

6. DIAGNOSTICS AND TROUBLESHOOTING	10
7. DRYER CHARACTERISTICS	11
8. PERFORMANCE GRAPHS	12
9. DIMENSIONS	12
9. WIRING DIAGRAM	13

Air dryers

DEH-500i / DEH-900i / DEH-1200i

Manufactured by DanVex (Finland)
www.danvex.fi



DEH-900i/1200i



DEH-500i

Introduction

Purpose

This user manual has been compiled to inform you about the equipment you have purchased and how to use it safely.

Content

Management contains general information on safety and applications, principle of operation, dehumidification process control, maintenance procedures, diagnosis and troubleshooting.

Copyright

We reserve all rights to update and clarify the information contained in this manual.

Warning!!!



The dehumidifier contains electrical components under tension. Please read this manual before operating the electrical installation to avoid errors that could result in personal injury, damage to equipment or electric shock! Our warranty is void and void if the unit has been misused, maintained or modified.

1 SAFETY AND APPLICATION

1.1 Safety of use

All models of dehumidifiers of this series are produced in compliance with the requirements of European safety standards and current regulations; the requirements for the safety of the operator and equipment were taken into account during design and production. This manual provides safety information and describes circumstances that may lead to abnormal situations. Such information is marked with a warning sign "dangerous". This manual also provides basic information on how to maintain the dehumidifier. It is for guidance only and does not remove the user's responsibility for compliance with personal safety requirements and local safety standards.

In equipment operation each user is obliged to follow the instructions below:

- observe technique safety when working with electrical equipment;
- follow the description and instructions in this manual to ensure protection user and equipment;
- before use, check the equipment for visible damage and performance;
- do not allow the use of the dehumidifier in explosive environments and rooms, as well as in places where the air contains various kinds of dust or aggressive substances: oils, salts, sulfur, chlorine, etc.;
- keep the heat exchangers clean and timely service the dehumidifier;
- do not use the installation without a filter;
- do not block the air intake and air supply grilles;
- do not wash the unit under running water;
- observe during transport and operation vertical installation position;
- empty on time container for condensate (when used);
- do not use the equipment if you suspect a malfunction;
- prevent deletion of warnings signs on the device;
- keep this manual next to the dryer.

1.2 Application area

DEH-i series dehumidifiers use the condensing method of dehumidification and are able to effectively dehumidify the air and automatically maintain the desired humidity level at atmospheric pressure in the range of 40-100% relative humidity and operating range temperatures from +5°C to +32°C.

This series of condensing dryers are widely used in the following fields:

- elimination of consequences flooding of various heated premises with water;
- heated warehouses for packaging and finished products;
- production of internal wet construction and finishing works;
- production and storage of confectionery products and foodstuffs;
- storage and aging of cheeses;
- drying fish, vegetables and fruits, starch;
- painting cameras;
- test laboratories;
- production facilities with high-precision equipment;
- rooms with open reservoirs and pools;
- premises that require frequent wet cleaning and laundry;
- pumping stations;
- production zones injection molding;
- and etc.

2 INFORMATION ABOUT YOUR DEVICE

2.1 Standards

The design of the dehumidifiers corresponds to the protection class IP22, IEC standard.

2.2 Description and principle of operation

The unit is designed for automatic and uninterrupted dehumidification and maintenance air humidity at atmospheric pressure.

The operation of the dehumidifier is based on the principle of condensation of moisture from the air. During operation of the dryer, moist air is sucked into the dryer by a fan and, passing through two heat exchangers of the compressor refrigeration machine, is first cooled in the "cold" heat exchanger (evaporator) to the dew point temperature with condensation, and then heated in the "warm" heat exchanger (condenser) and is discharged from the dehumidifier into the room to be dried. The moisture released from the air in the form of condensate flows into the inner tray, and then by gravity, at the user's choice, is discharged either into the built-in removable tank or directly into the sewer system.

Dehumidifier management and control carried out through the control panel equipped with an LCD display. The display can show current and adjustable parameters, operating modes, as well as service information in case of a malfunction.

In the course of work through a dehumidifier there is a continuous repeated circulation of air and its humidity in the room gradually decreases. Due to the design of the dryer in a single unit, the air temperature at the outlet of the dryer in dehumidification mode is always higher than the air temperature at the inlet to the dryer by about 5°C.

It should also be borne in mind that the performance of the dehumidifier directly depends on the humidity and temperature of the air being dried. The lower the temperature and air humidity, dryer performance will be lower.

The dehumidifier is equipped with a function to control the presence of a removable tank and the level of its filling. If the tank is empty or full, the display will show "Tank Full" and the dehumidifier will automatically turn off until the cause is corrected.

To use a removable tank to collect condensate, it is necessary to lead the hose from the condensate collection tray into the tank. To drain condensate directly into the sewer, it is necessary to connect the hose from the condensate tray from the inside to the fitting on the side wall of the dehumidifier, and use the supplied corrugated hose from the fitting to the sewer from the outside. In this case, the dehumidifier can operate continuously, without stopping to drain the condensate from a filled tank.

When freezing the heat exchanger during the operation of the dehumidifier, the automation switches off the compressor for defrosting, the fan continues to work. After the defrosting of the heat exchanger is completed, the compressor turns on automatically and the air dehumidification continues. Operating modes are displayed on the LCD display of the control panel.

The dehumidifier is equipped with a removable, washable G3 filter to clean the incoming air. The use of a dryer without a filter is prohibited due to contamination of the heat exchanger, subsequent corrosion of its elements and, as a result, depressurization of the system.

Schematic diagram of the dehumidifier operation

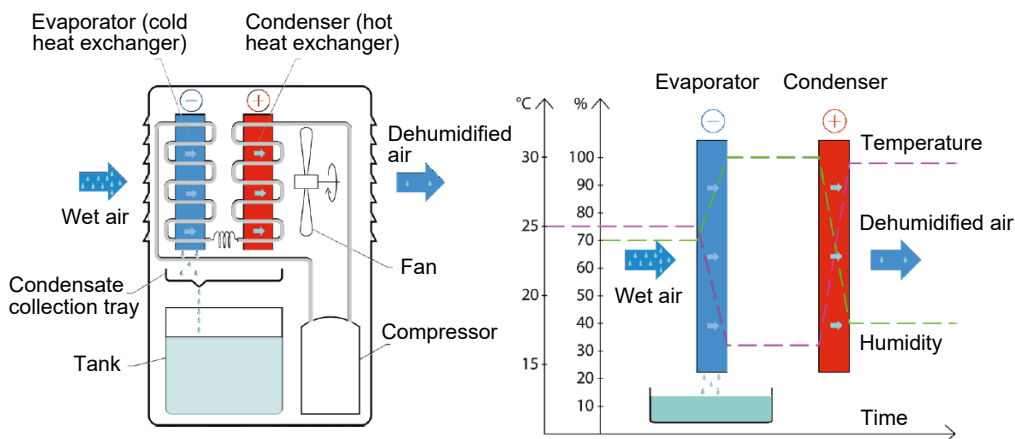

2.3 Design

The dehumidifier has a metal, corrosion-resistant housing, powder-coated method. In the lower part of the body, behind a removable panel, there is a condensate collection tank. In the upper part of the housing there is an incoming air filter, which is fixed with a removable grille.

For ease of transportation, the dryer is equipped with tubeless wheels and high transport handle.

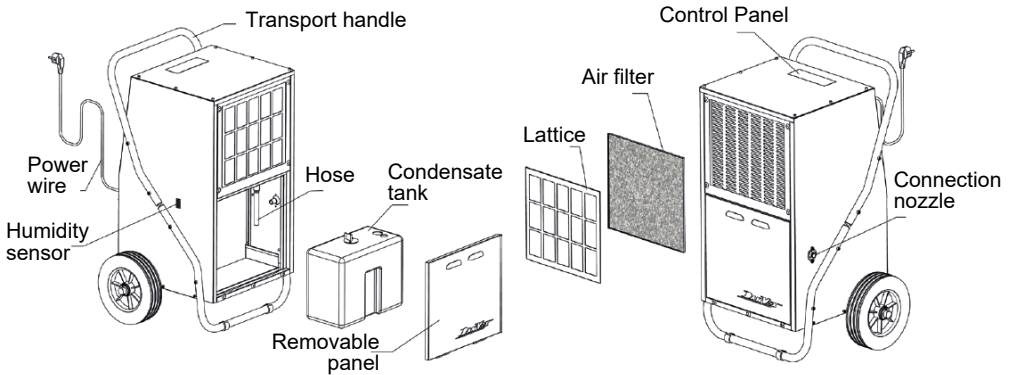

3 MOVEMENT AND INSTALLATION SITE

The equipment is equipped with transport wheels and a handle for easy moving to the place of operation.

For optimal, economical and safe operation of the dryer, the following recommendations:

- avoid physical damage to the unit when moving to the site exploitation;
- do not place the dehumidifier in close proximity to radiators or other sources of heat;
- install the dehumidifier on a level surface in a vertical position to properly drain the condensate discharged into the built-in tank or from the dehumidifier;
- if possible, place the dehumidifier in the center of the room to be dried or in the middle of a long wall to ensure optimal air circulation;
- do not cover or block the ventilation grilles of the unit for unhindered circulation of the dried air through the dryer;
- close windows, doors and, if possible, limit the ventilation performance in the room being dried to avoid the influx of moist air from the street or adjacent premises.

4 STARTING AND OPERATION

4.1 Electrical connection



All work on electrical equipment must be carried out in accordance with the safety standards of the country in which the equipment is used!

- it is forbidden to connect the dehumidifier to the mains, the power and frequency of which are outside the nominal values of the dehumidifier;
- when using extension cables, they must be fully extended, grounded and of sufficient conductor cross-section.

4.2 Control Panel

The control panel is designed to set the dehumidification parameters and control the operation of the unit. The panel contains waterproof control buttons and an LCD display. The buttons are used for on/off dryer, tasks required humidity level, as well as to control the timer. The LCD display shows the operating modes, the level of required humidity and the current air parameters at the installation site dryer.

Control buttons:

ON/OFF - enable/ disable the dehumidifier;

TIMER - enable/ disable the timer to disable or enable;

+ - increasing the humidity parameter or the timer parameter;

- - decreasing the humidity setting or the timer setting.



4.3 How to operate and set parameters

The dehumidifier is switched on by pressing the ON/OFF button once, the dehumidifier emits a short beep and the LCD display lights up.

Adjust the desired humidity level, which is supposed to be supported, with the + or - buttons.

The % humidity reading on the display will change during the setup process.

If the current humidity level higher than the set value by at least 2-3%, the dehumidifier will start working. After turning on the installation, it works in a fully automatic mode. The dehumidifier will turn off when the set humidity level is reached.

Order automatic start of components when the dehumidifier is switched on:

1. Fan start
2. Compressor start after a short pause

Installation equipped with a safety device that prevents the compressor from restarting when restarted immediately after shutdown, thus preventing damage to the compressor.

The compressor start delay is 3 minutes.

The timer is set using the **TIMER**, **+ / -** buttons and is possible both to turn off the dehumidifier from the working state, and to turn on the dehumidifier from the non-working state.

Settings are made in the corresponding modes:

TO DISABLE - in operating mode, press **TIMER** once, then **+/-** to set time in hours (range 1–24 hours);

ON - in idle mode, press **TIMER** once, then **+/-** to set time in hours (range 1–24 hours).

Attention:

- The dehumidifier will not start if the humidity level set in the settings is higher than current humidity;
- The dehumidifier will not start if the tank is full or missing;
- When operating in cold conditions, the compressor of the dryer may turn off to perform a defrost, and the defrost indicator will light up on the display  ;
- The display shows humidity in the range from 30% to 90%;
- If the dehumidifier is not to be used for a long time, unplug it.

5 MAINTENANCE



Before starting any maintenance work maintenance, be sure to disconnect the dehumidifier from the mains!

5.1 Introduction

It is important to regularly inspect, maintain and clean the main components of the dryer to ensure a long service life and trouble-free operation. The frequency of maintenance depends on the operating conditions of the dryer. Thus, the maintenance cycle can be determined based on actual operation. Incomplete and incorrect maintenance can reduce efficiency dryer or damage it.

5.2 Frame

Dust and other substances must not accumulate on the body of the dryer. It is recommended to clean the case with a dry or slightly damp cloth without the use of solvents or abrasive detergents. Use only non-aggressive cleaning agents, even if the unit is heavily soiled.

It is forbidden to clean the unit under the jet water!

5.3 Filter

The dehumidifier is equipped washable coarse air filter at the inlet. It protects the dryer heat exchangers from fluff and household dust. Do not run the dryer without a filter.

It is recommended to clean the filter as it becomes clogged, but at least once every 2 weeks.

5.4 Heat exchanger

With the right operating the dryer with the air filter installed, the heat exchanger does not require any maintenance.

However, when operating in dusty environments, which are not normal operating conditions, it may be necessary to clean the heat exchanger. In such cases, it is necessary to clean the heat exchanger in a jet of warm water without the use of solvents and aggressive detergents, with preliminary disassembly of the dryer housing, protection of electrical components and subsequent blowing of the heat exchanger with compressed air.

5.5 Fan motor

The motor is equipped with rolling bearings, service life corresponding to the service life of the engine. During operation, dust and moisture can enter the bearing, wear out and reduce its service life. It is recommended to lubricate or replace the bearing depending on the intensity of use, but at least once every 2 years.

5.6 Compressor refrigeration system

The compressor system is a closed circuit system and does not require special maintenance. If necessary, all diagnostic and maintenance activities must be carried out by a specialist or an authorized service center.

6 DIAGNOSTICS AND TROUBLESHOOTING

For high quality and long lasting during operation, the installation was subjected to control and testing during the manufacturing process. However, in case of problems during operation, please use the following recommendations:

State	Possible reason	Actions foreliminate
Dehumidifier does not turn on (display does not light up)	<ul style="list-style-type: none"> • no power supply • fuse failure 	<ul style="list-style-type: none"> • check the connection and mains voltage • check the fuse
Dehumidifier does not start (display highlighted)	<ul style="list-style-type: none"> • high humidity setting • tank full or missing • launch after an emergency blackouts • freezing of the heat exchanger • humidity sensor is defective • fan motor out of order 	<ul style="list-style-type: none"> • reduce humidity settings • empty and install tank • delay start compressor 3 minutes • check message on the display and wait for the defrost • check for an error on the display • check fan rotation
No or little condensation (fan running)	<ul style="list-style-type: none"> • low air humidity or temperature • filter or heat exchanger clogged • refrigerant leak • compressor malfunction 	<ul style="list-style-type: none"> • check air parameters for correct operation • clean the filter or heat exchanger • check for an error on the display • check the start of the compressor by the sound and the presence of an error on the display

If there is a problem with the dryer control system or the refrigeration circuit, the display will show an error code instead of the temperature reading.

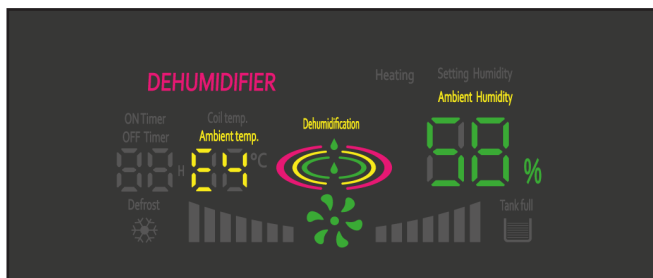

List of errors:

- E1 - exchanger temperature sensor defective
- E3 - temperature sensor and air humidity is defective
- E4 (blinks) - refrigeration system malfunction: refrigerant leak or wrong operation of the compressor
- E5 - high temperature of the refrigerant in the system



Operation of the dehumidifier with a clogged filter or heat exchanger leads to overheating of the compressor and its failure, which is not covered by the warranty!

7. DRYER CHARACTERISTICS

Model	DEH-500i	DEH-900i	DEH-1200i
Productivity (at 30°C/ 80% RH), l/day	50	90	120
Operating temperature range, °C	+5 .. +32		
Dehumidification range, RH%	40 .. 95		
Working air, m ³ /hour	300	500	700
Condensate tank capacity, liter	6,5	14	14
Operating current, A	4,3	6	5,8
Power consumption, kW	950	1350	1350
Voltage / frequency	230V / 50Hz		
Refrigerant	R32*250g	R32*400g	R32*500g
Noise level, dB(A)	< 64	< 64	< 64
Protection level	IP22		
Air filter class	G3		
Overall dimensions, mm (depth*width*height)	на эскизе		
Weight, kg	34	55	62

8. CHARTS PERFORMANCE

DEH-500i

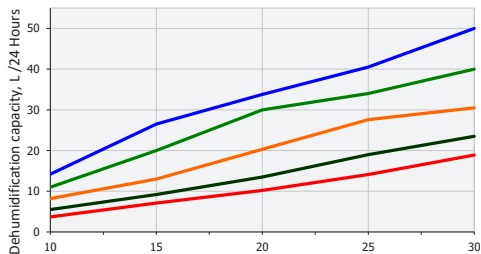

DEH-900i

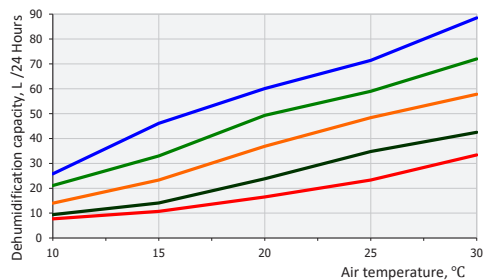

DEH-1200i

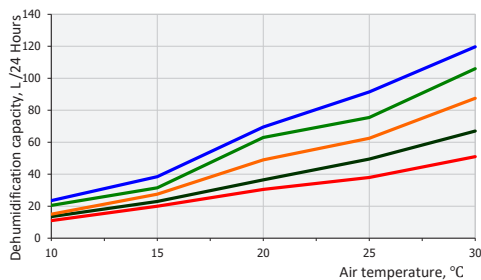

— 40% — 50% — 60% — 70% — 80%

9. DIMENSIONS

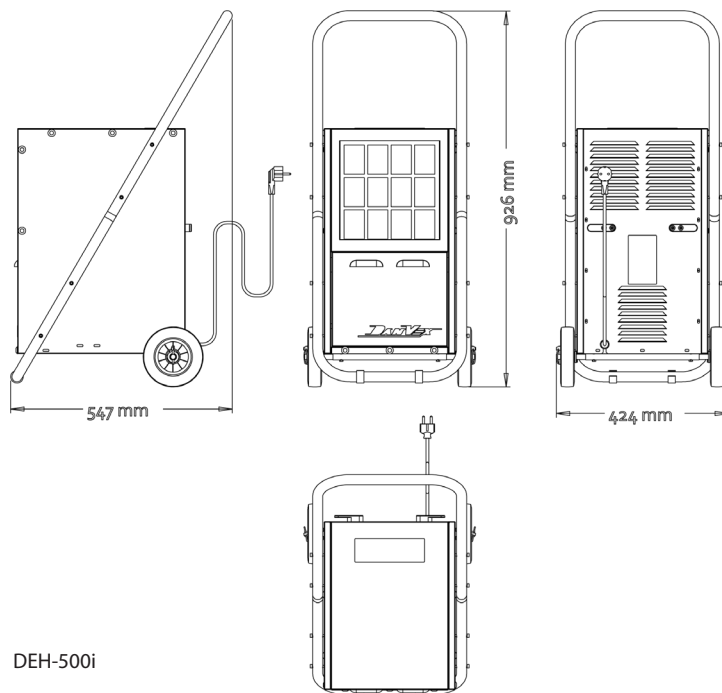

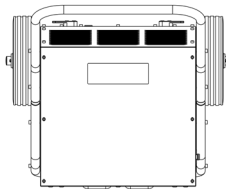
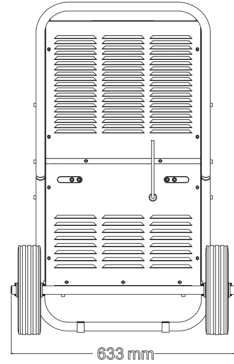
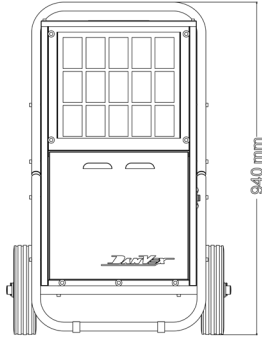
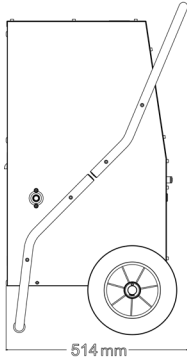

DEH-900i/1200i

10. ELECTRIC SCHEME

